

MAGNETIC SENSOR SYSTEMS

Pull Type D-Frame Solenoid

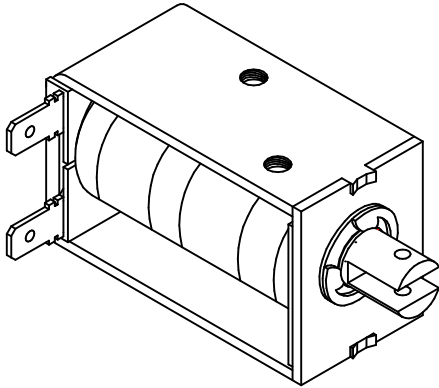

Series S-18-100-Q
0.84" X 1.00" X 1.75"

TOTAL WEIGHT: 3.8 OUNCES

PLUNGER WEIGHT: 0.5 OUNCES

duty cycle	1	1/2	1/4	1/10
maximum "ON" time, (Sec.)	∞	200	50	20
watts	7.5	15	30	75
approximate ampere turns	1100	1550	2200	3450

AWG number	resistance	volts DC	volts DC	volts DC	volts DC
23	1.8	3.7	5.3	7.4	11.7
24	2.7	4.4	6.2	8.8	13.9
25	4.4	6.0	8.4	11.9	18.8
26	7.4	7.5	10.6	14.9	23.6
27	11.0	8.8	12.5	17.6	27.9
28	18.7	11.7	16.6	23.4	37.0
29	30.3	15.0	21.2	30.0	47.5
30	46.1	18.2	25.7	36.4	57.6
31	76.9	23.9	33.8	47.9	75.7
32	117	30.1	42.6	60.3	95.3
33	185	36.5	51.5	72.9	115
34	286	46.9	66.3	93.9	148
35	477	61.0	86.2	122	193
36	705	73.9	104	148	234
37	1105	90.6	128	181	286
38	1643	111	157	223	352
39	2915	148	209	296	467
40	4610	186	263	372	588

HEAT SINK: For proper heat dissipation, body of solenoid should be mounted on an equivalent of 4.0" x 4.0" x 1/8" aluminum plate in an unrestricted flow of air.

MAGNETIC SENSOR SYSTEMS

S-18-100Q

MECHANICAL DIMENSIONS

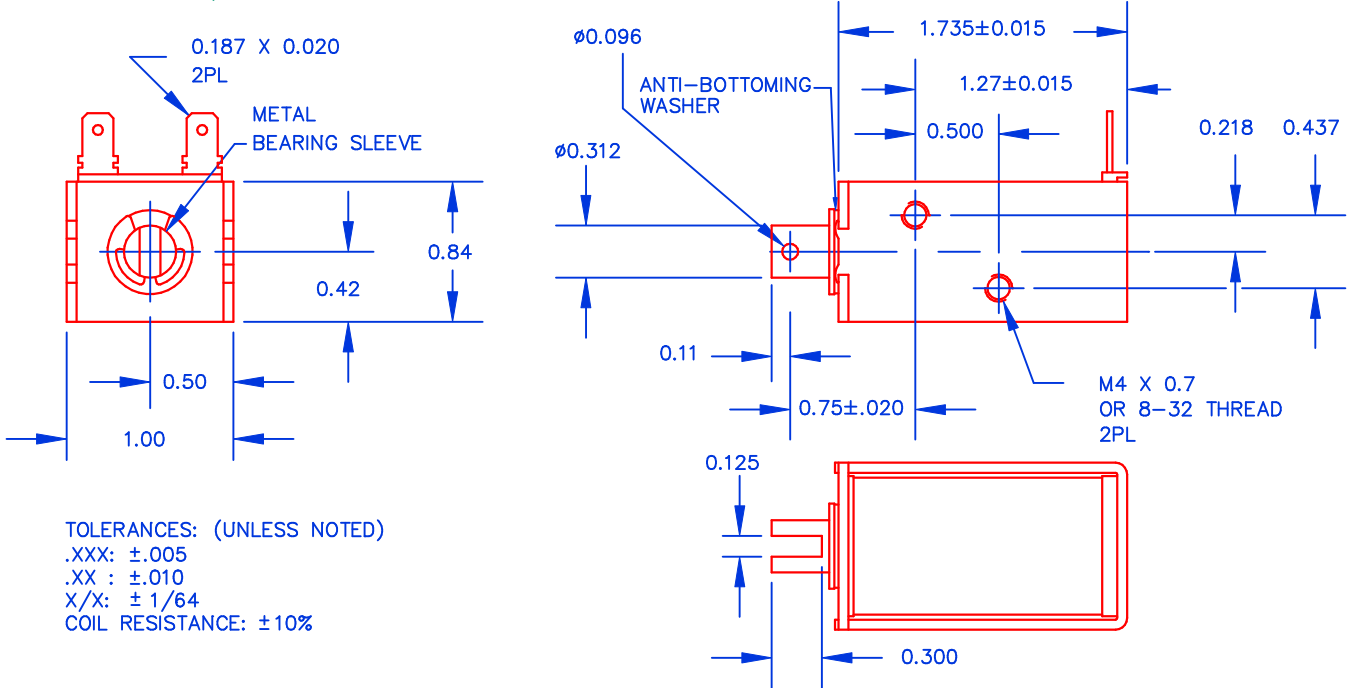

TOLERANCES: (UNLESS NOTED)
 .XXX: ±.005
 .XX : ±.010
 X/X: ± 1/64
 COIL RESISTANCE: ±10%

SOLENOID SHOWN ENERGIZED

TYPICAL PULL FORCE VERSUS STROKE

