

MAGNETIC SENSOR SYSTEMS

Pull Type C-Frame Solenoid

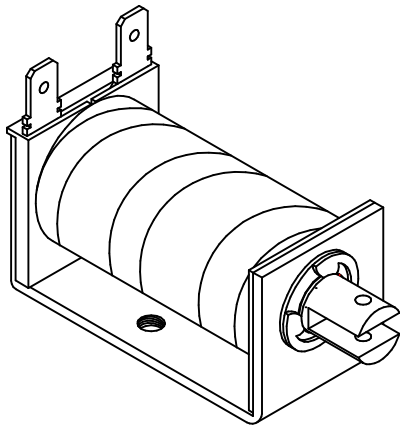

Series S-17-85-Q
0.84" X 0.92" X 1.75"

TOTAL WEIGHT: 3.7 OUNCES

PLUNGER WEIGHT: 0.5 OUNCES

duty cycle	1	1/2	1/4	1/8
maximum "ON" time, (Sec.)	∞	100	15	10
watts	5	10	20	40
approximate ampere turns	1060	1500	2120	3000

AWG number	resistance	volts DC	volts DC	volts DC	volts DC
23	1.8	3.0	4.2	6.0	8.5
24	2.7	3.7	5.2	7.3	10.4
25	4.4	4.7	6.6	9.4	13.3
26	7.4	6.1	8.6	12.2	17.2
27	11.0	7.4	10.5	14.8	21.0
28	18.7	9.7	13.7	19.3	27.3
29	30.3	12.3	17.4	24.6	34.8
30	46.1	15.2	21.5	30.4	42.9
31	76.9	19.6	27.7	39.2	55.5
32	117	24.2	34.2	48.4	68.4
33	185	30.4	43.0	60.8	86.0
34	286	37.8	53.5	75.6	107
35	477	48.8	69.1	97.7	138
36	705	59.4	84.0	119	168
37	1105	74.3	105	149	210
38	1643	90.6	128	181	256
39	2915	121	171	241	341
40	4610	152	215	304	429

HEAT SINK: For proper heat dissipation, body of solenoid should be mounted on an equivalent of 4.0" x 4.0" x 1/8" aluminum plate in an unrestricted flow of air.

MAGNETIC SENSOR SYSTEMS

S-17-85Q

MECHANICAL DIMENSIONS

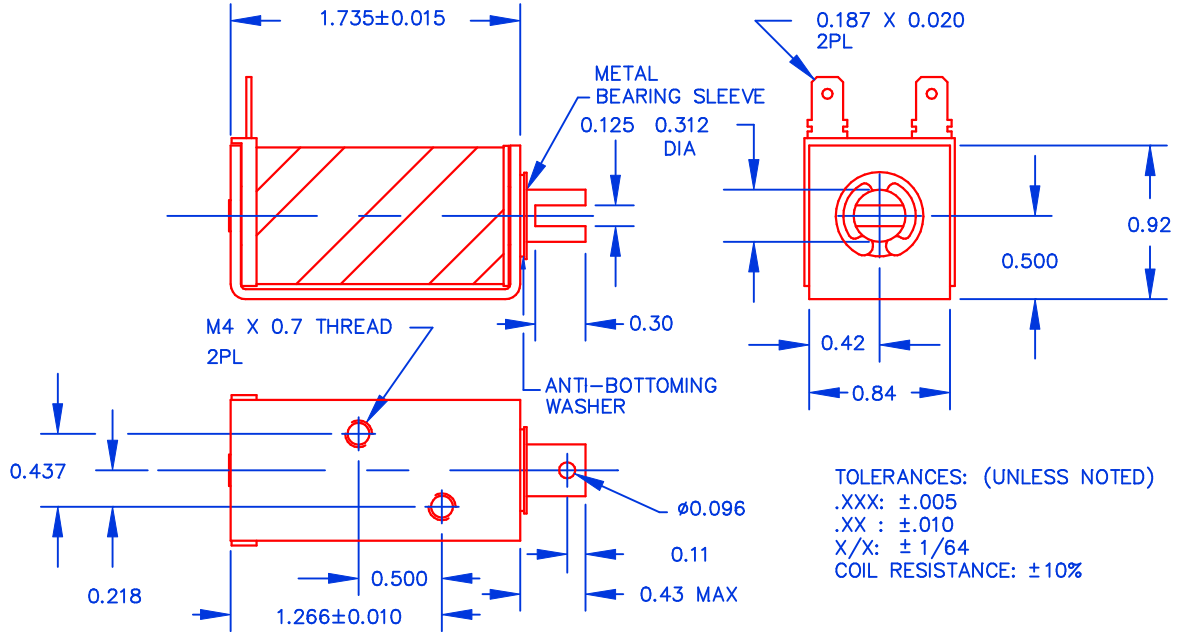

SOLENOID SHOWN ENERGIZED

TYPICAL PULL FORCE VERSUS STROKE

