

MAGNETIC SENSOR SYSTEMS

Pull Type Tubular Solenoid

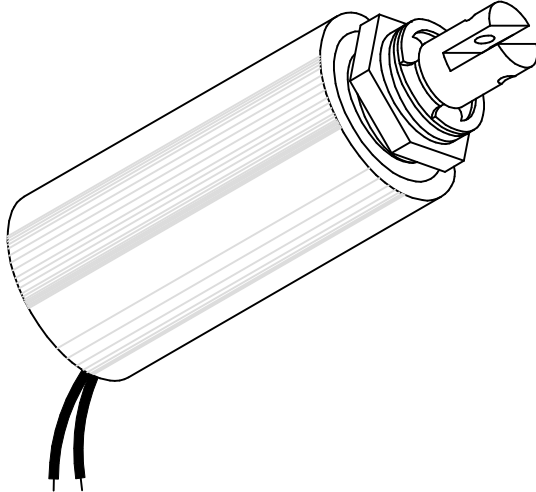

Series S-25-125
 1 1/4" DIA X 2 1/2"

TOTAL WEIGHT: 11.2 OUNCES

PLUNGER WEIGHT: 1.9 OUNCES

duty cycle	1	1/2	1/4	1/10
maximum "ON" time, (Sec.)	∞	410	100	30

watts	11	22	44	110
approximate ampere turns	1410	2000	2820	4460

AWG number	resistance	volts DC	volts DC	volts DC	volts DC
20	0.97	3.2	4.5	6.3	10.0
21	1.38	4.0	5.6	7.9	12.5
22	2.49	5.1	7.2	10.2	16.1
23	3.49	6.2	8.8	12.5	19.7
24	6.06	8.1	11.5	16.2	25.5
25	9.89	10.3	14.5	20.5	32.4
26	16.6	13.0	18.4	25.9	41.0
27	24.5	16.1	22.8	32.2	50.9
28	36.9	20.4	28.9	40.8	64.5
29	61.8	25.5	36.1	51.0	80.6
30	93.3	31.5	44.6	62.9	99.5
31	144	40.3	57.1	80.6	127
32	210	49.4	70.0	98.7	156
33	357	63.5	90.0	127	201
34	553	82	116	164	259
35	993	105	149	210	332
36	1460	131	186	263	415
37	2406	160	227	320	506

HEAT SINK: For proper heat dissipation, body of solenoid should be mounted on an equivalent of 6.0" x 6.0" x 1/8" aluminum plate in an unrestricted flow of air.

MAGNETIC SENSOR SYSTEMS

S-25-125

MECHANICAL DIMENSIONS

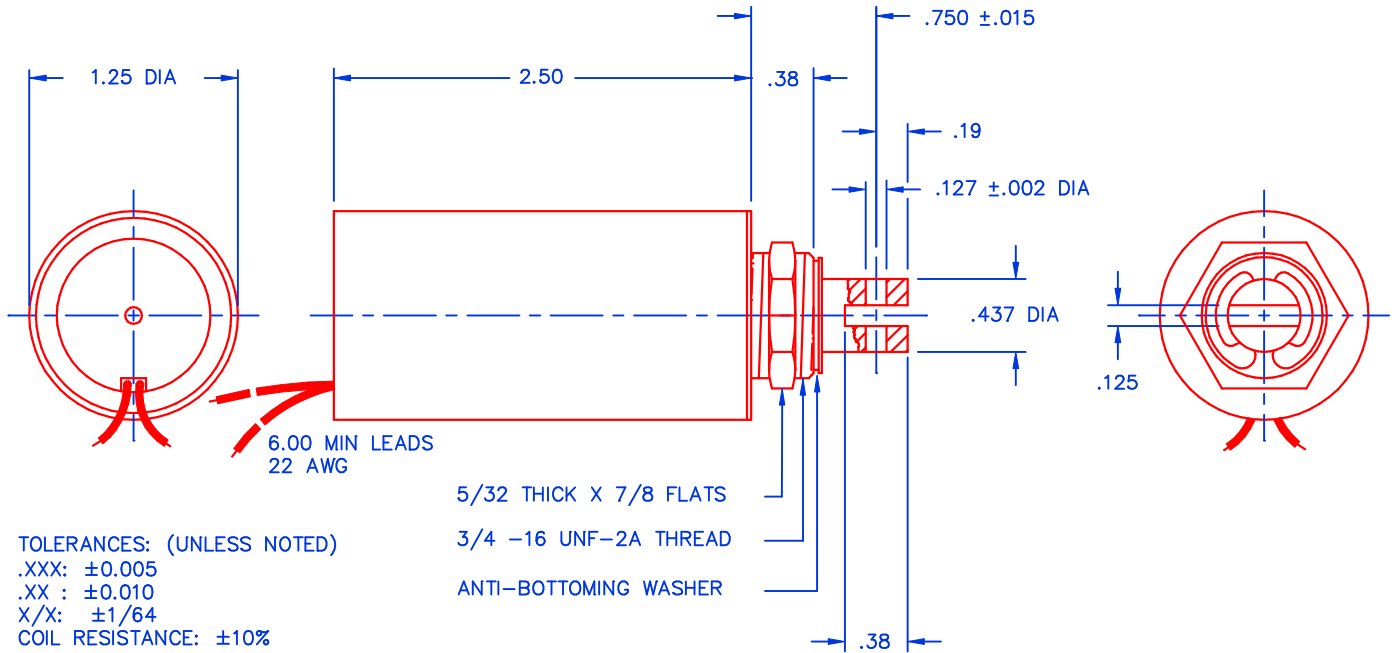

SOLENOID SHOWN ENERGIZED

TYPICAL PULL FORCE VERSUS STROKE

