

MAGNETIC SENSOR SYSTEMS

Push Type Tubular Solenoid

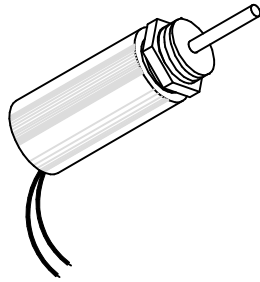

Series S-10-50-H
1/2" DIA X 1.0"

TOTAL WEIGHT: 0.77 OUNCES

PLUNGER WEIGHT: 0.12 OUNCES

duty cycle	1	1/2	1/4	1/10
maximum "ON" time, (Sec.)	∞	75	20	5
watts	4	8	16	40
approximate ampere turns	480	670	950	1500

AWG number	resistance	volts DC	volts DC	volts DC	volts DC
25	0.48	1.4	2.0	2.8	4.5
26	0.86	1.9	2.6	3.7	5.9
27	1.20	2.3	3.2	4.5	7.1
28	2.25	3.0	4.2	5.9	9.4
29	3.00	3.4	4.8	6.8	10.7
30	5.80	4.9	6.8	9.7	15.3
31	7.85	5.5	7.8	11.0	17.3
32	12.1	6.7	9.5	13.4	21.2
33	24.8	10.3	14.5	20.5	32.3
34	33.7	11.7	16.5	23.4	36.9
35	54.8	15.2	21.4	30.2	47.8
36	81.6	17.9	25.2	35.5	56.1
37	135	23.9	33.6	47.5	75.0
38	197	28.9	40.8	57.6	91.0
39	367	37.6	53.0	74.8	118
40	520	46.0	64.8	91.5	145
41	808	56.1	79.1	112	177
42	1248	70.7	99.5	141	222

HEAT SINK: For proper heat dissipation, body of solenoid should be mounted on an equivalent of 2.0" x 2.0" x 1/8" aluminum plate in an unrestricted flow of air.

MAGNETIC SENSOR SYSTEMS

S-10-50-H

MECHANICAL DIMENSIONS

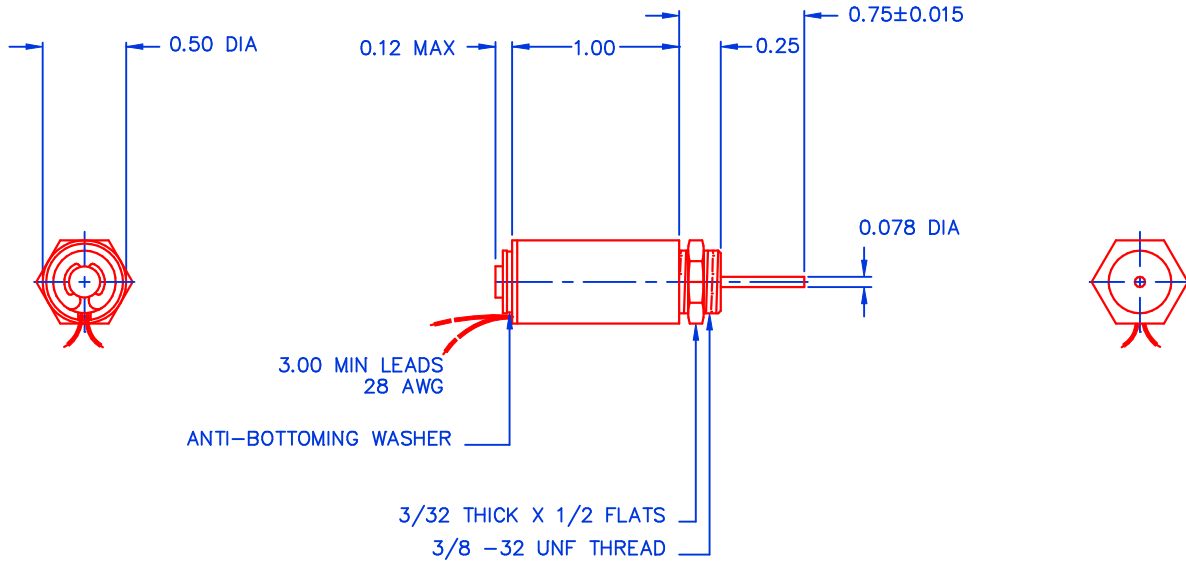

TOLERANCES: (UNLESS NOTED)

.XXX: ±.005

.XX : ±.010

X/X: ± 1/64

COIL RESISTANCE: ±10%

SOLENOID SHOWN ENERGIZED

TYPICAL PUSH FORCE VERSUS STROKE

